





-  Ambient, unheated
-  Electrically heated 3-18 kW
-  Water heated

Lengths: 1, 1,5 and 2 metres



## Thermozone® AD 200 A/E/W

### Air curtains for installation heights up to 2,5 metres

AD200 is an air curtain with a modern design for mounting over entry doors and other small doors with a height of up to 2,5 metres.

AD200 creates an air barrier, which effectively prevents cold draughts and ensures comfortable heating inside the door. Energy losses through openings are reduced, which means considerable savings. An adjustable air blower grille makes it possible to direct the air for an optimal air curtain effect.

An AD200 with heater also contributes to the heating of a room. With AD200A without heat it is possible to significantly reduce energy losses through openings to refrigerated rooms or openings to air conditioned rooms.

AD200 can be built into false ceilings. For wide openings it is possible to mount several units beside each other and control them with a single thermostat and control panel. The three different product lengths make it possible to cover openings of different widths.

AD210C is a compact model with built-in thermostat and control panel and equipped with cable and plug (AD210C05 cable only).

- Low sound level.
- Corrosion proof housing made of hot zinc-plated and powder coated steel panels. Colour: RAL 9016.
- Adjustable distance between mounting brackets.
- Easy to mount.
- Compact and easily positioned.
- Easy maintenance.
- Optimized airflow with Thermozone technology.

#### Air velocity profile

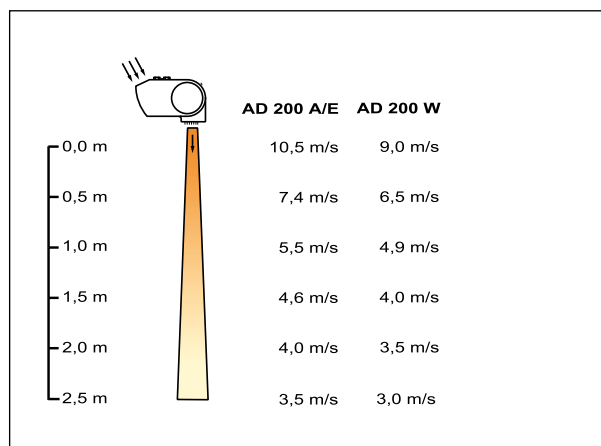

### Technical specifications | Thermozone AD 200 A, ambient unheated

Type	Output [kW]	Airflow [m³/h]	Sound level*1 [dB(A)]	Voltage [V]	Amperage [A]	Length [mm]	Weight [kg]
AD210A	0	900/1400	41/51	230V~	0,5	1020	12
AD215A	0	1300/2100	43/53	230V~	0,6	1530	16
AD220A	0	1800/2800	44/54	230V~	1,0	1960	28

### Technical specifications | Thermozone AD 200 E/C, electrically heated

Type	Output steps [kW]	Airflow [m³/h]	Sound level*1 [dB(A)]	$\Delta t^{*2}$ [°C]	Voltage [V]	Amperage [A]	Length [mm]	Weight [kg]
AD210C03	0/2/3	900/1400	41/47	10/6	230V~	13,5	1020	13
AD210C05	0/2,3/4,5	900/1400	41/47	15/10	230V~	20,1	1020	13
AD210E03	0/1,5/3	900/1400	41/51	10/6	230V~/400V3N~*3	13,5/4,8	1020	13
AD210E06	0/3/6	900/1400	41/51	20/13	400V3N~*3	9,2	1020	14
AD210E09	0/4,5/9	900/1400	41/51	30/19	400V3N~*3	13,5	1020	16
AD215E05	0/2,3/4,5	1300/2100	43/53	10/6	400V3N~*3	7,1	1530	19
AD215E09	0/4,5/9	1300/2100	43/53	20/13	400V3N~*3	13,6	1530	23
AD215E14	0/6,7/13,5	1300/2100	43/53	34/21	400V3~ +230V~	20,0	1530	23
AD220E12	0/6/12	1800/2800	44/54	20/13	400V3~ +230V~*4	18,2	1960	32
AD220E18	0/9/18	1800/2800	44/54	30/19	400V3~ +230V~*4	26,9	1960	32

### Technical specifications | Thermozone AD 200 W, water heated

Type	Output*5 [kW]	Airflow [m³/h]	Sound level*1 [dB(A)]	$\Delta t^{*2,5}$ [°C]	Water volume [l]	Voltage [V]	Amperage [A]	Length [mm]	Weight [kg]
AD210W	7	750/1200	38/49	23/19	0,5	230V~	0,5	1020	15
AD215W	12	1100/1800	40/51	24/19	0,9	230V~	0,6	1530	21
AD220W	15	1500/2400	41/52	23/19	1,1	230V~	1,0	1960	31

\*1) Conditions: Distance to the unit 5 metres. Directional factor: 2. Equivalent absorption area: 200 m².

\*2)  $\Delta t$  = temperature rise of passing air at maximum heat output and lowest/highest airflow.

\*3) Or 400V3~ + 230V~ if the current is greater than 16 A.

\*4) Heating elements are divided and powered by two separate supplies.

\*5) Applicable at water temperature 80/60 °C, air temperature in +15 °C.

Protection class AD200A/W: (IP21)

Protection class AD200E: (IP21)

Approved by SEMKO and CE compliant.



## Dimensions

### Ambient / Electric

#### AD210/215A/E

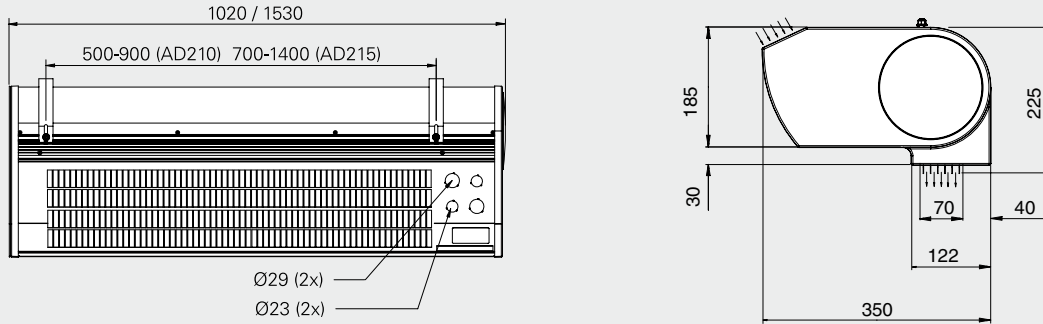

#### AD220A/E

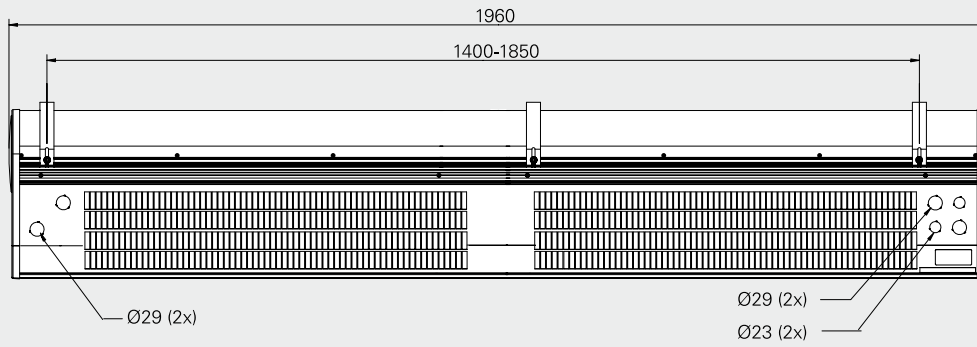

### Water

#### AD210/215W

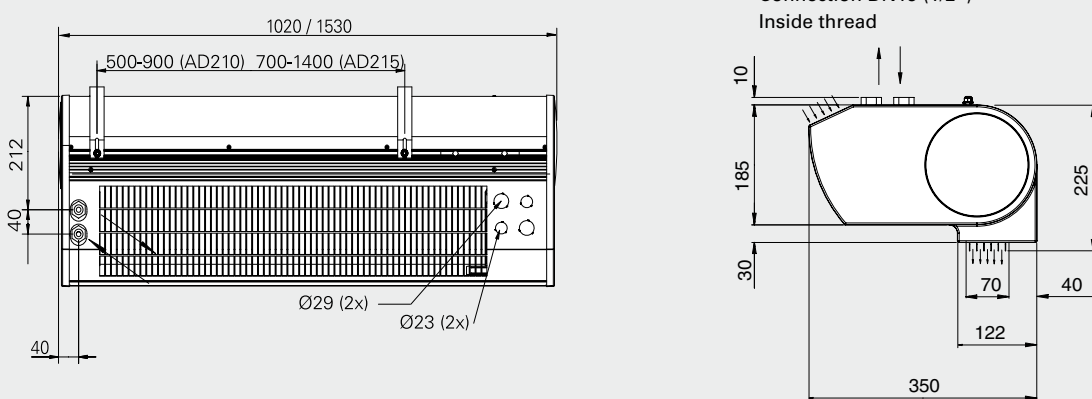

#### AD220W

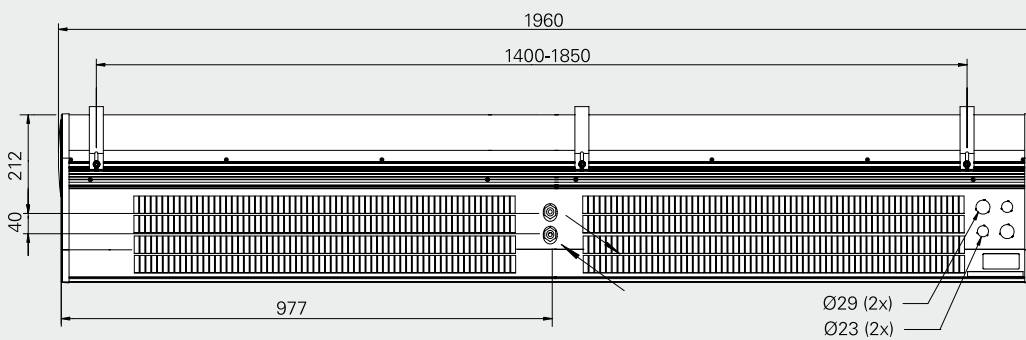

## Mounting and installation

### Mounting

Thermozone AD200 can be permanently mounted on the wall or on the ceiling using threaded drop rods together with suspension kit, see next page. The air curtain can also be built into false ceilings, see Fig. 2. The unit can only be mounted horizontally, with the air outlet directed downwards. Minimum distance from outlet to flammable material is 50 mm.

The distance between the mounting brackets is adjustable, which simplifies mounting. Brackets suitable for each unit are included on delivery. The 2 metre units should be fitted using three fixing points.

For best effect the air curtain should cover the full width of the door and be placed as close to the opening as possible. For wider openings it is possible to place several units beside each other to create a continuous air curtain. The units should then be positioned as close together as possible.

### Connection AD 200E ⚡

The appliance should be isolated by a triple pole switch with at least 3 mm breaking gap. Connection is made through knock outs on the top side of the unit. For connection to the supply terminal block, a cable of maximum 16 mm<sup>2</sup> is used. For connection to the control terminal block, a cable of maximum 4 mm<sup>2</sup> is used. For units with electrical heating, power and control should normally be supplied separately. For smaller units (current below 16 A), the supply could be common for both power and control, see technical specifications. For AD220E heating elements are divided and powered by two separate supplies. See wiring diagrams and dimension drawings.

### Connection AD 200W ⚡

The control cable is connected via a knock out on the top side of the unit to the right (seen from inside the building). Connections (DN15 (1/2")), inside thread) to the water heating coil are located on the top of the unit to the left (seen from inside the building). See wiring diagrams and dimension drawings.

See over page for control kits and the chapter on Controls and accessories for further information.

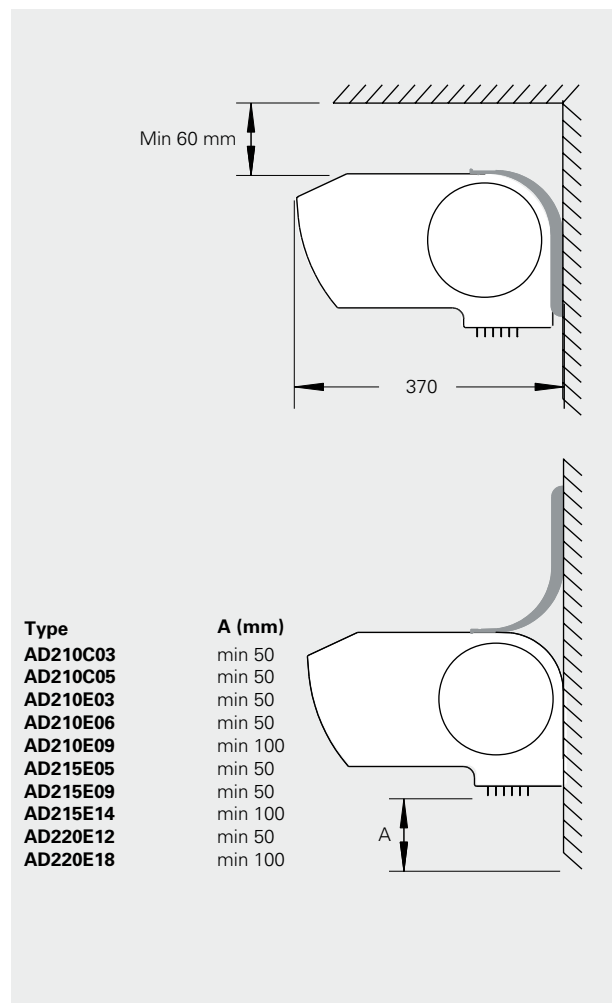

Fig. 1: Minimum mounting distance

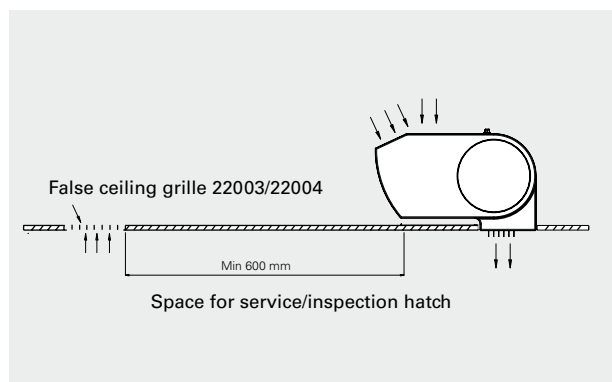
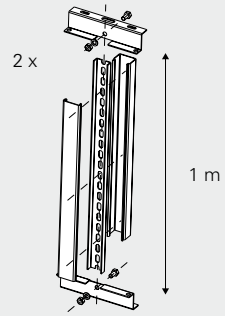
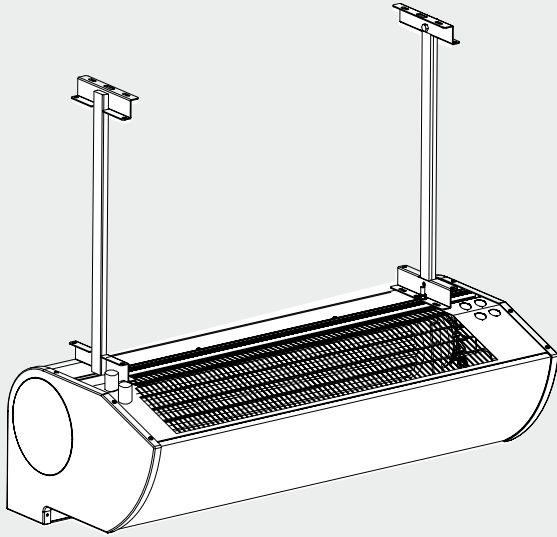

Fig. 2: Mounting in a false ceiling

## Mounting with suspension kit (extra)

### ADPK1



### ADPF1

Threaded bars and M8 nuts are not included on delivery

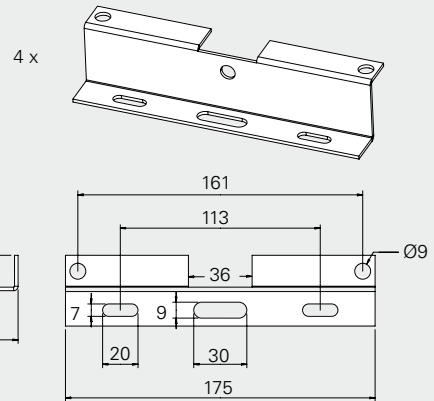
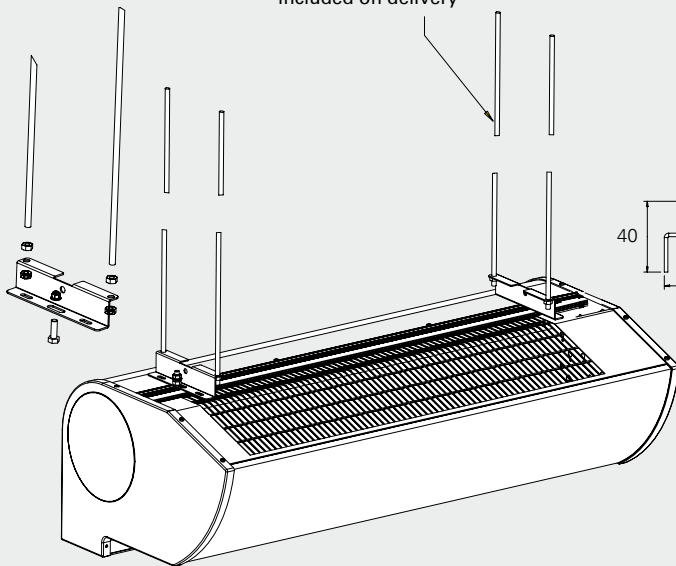

## Complete control kits

### Ambient ✨

Airflow is controlled manually.

Complete control kit:

- CB30N, control box, controls the air flow in 3 steps

### Electric ⚡

#### Level 1

Airflow is controlled manually. Room thermostat controls the heat output in 2 steps.

Control kit CK01E:

- CB32N, control box, controls the airflow in 3 steps and heat output in 2 steps
- RTI2, 2-step room thermostat

#### Level 2

Airflow and heat output are controlled automatically based on the opening of the door and the room temperature.

When the door is open the fan runs on high speed, when the door closes the fan will continue to run for the desired time (2s–10 min.) set on MDC. When the door is closed the fan runs on low speed if there is a need for heating, if not the fan is switched off.

The room thermostat controls the heat output. E.g. the thermostat is set on 23 °C and the difference between the steps 4 °C. The thermostat will activate below 19 °C when the door is closed. When the door opens, the thermostat will activate below 23 °C and normally the heat is switched on.

Control kit CK02E:

- CB32N, control box, controls the airflow in 3 steps and heat output in 2 steps
- MDC, magnetic door contact with time delay
- RTI2, 2-step room thermostat

#### Level 3

Airflow and heat output are controlled automatically based on the opening of the door, outdoor temperature and the room temperature.

The system is based on an advanced microprocessing regulator in an attractive design.

All parameters are pre-programmed for easy and quick installation.

Control kit CK03:

- ADEA, regulator (complete with outdoor sensor, built-in room sensor and door contact)
- ADEAIS, indoor sensor
- ADEAEB, control board, for external mounting

Read more about operation and usage of ADEA in chapter on Controls and accessories.

### Water 💧

#### Level 1

Airflow is controlled manually. Room thermostat controls the heat output via actuator/valve.

Control kit CK01W:

- CB30N, control box, controls the airflow in 3 steps
- T10, room thermostat IP30

Note! A set of valves VR20 or VR25 or actuator+valve SD20+TVV20 or TVV25 should be added for a complete control kit.

#### Level 2

Airflow and heat output are controlled automatically based on the opening of the door and the room temperature.

When the door is open the fan runs on high speed, when the door closes the fan will continue to run for the desired time (2s–10 min.) set on MDC. When the door is closed the fan runs on low speed if there is a need for heating, if not the fan is switched off.

The room thermostat controls the heat output. E.g. the thermostat is set on 23 °C and the difference between the steps 4 °C. The thermostat will activate below 19 °C when the door is closed. When the door opens, the thermostat will activate below 23 °C and normally the heat is switched on.

Control kit CK02W:

- CB30N, control box, controls the airflow in 3 steps
- MDC, magnetic door contact with time delay
- RTI2, 2-step room thermostat

Note! A set of valves VR20 or VR25 or actuator+valve SD20+TVV20 or TVV25 should be added for a complete control kit.

#### Level 3

Airflow and heat output are controlled automatically based on the opening of the door, outdoor temperature and the room temperature.

The system is based on an advanced microprocessing regulator in an attractive design.

All parameters are pre-programmed for easy and quick installation.

Control kit CK03:

- ADEA, regulator (complete with outdoor sensor, built-in room sensor and door contact)
- ADEAIS, indoor sensor

- ADEAEB, control board, for external mounting  
Note! A set of valves VR20 or VR25 or actuator+valve SD20+TVV20 or TVV25 should be added for a complete control kit.

Read more about operation and usage of ADEA in chapter on Controls and accessories.

## Output charts water

Incoming / outgoing water temperature 90/70 °C								
			Incoming air temp.= +15 °C			Incoming air temp. = +20 °C		
Type	Fan position	Airflow [m³/h]	Output [kW]	Outgoing air temp. [°C]	Water flow [l/s]	Output [kW]	Outgoing air temp. [°C]	Water flow [l/s]
AD210W	max	1200	9,3	37	0,11	8,5	41	0,10
	min	750	7,1	43	0,08	6,5	45	0,07
AD215W	max	1800	14,3	38	0,17	13,1	41	0,15
	min	1100	10,8	44	0,12	10,0	46	0,11
AD220W	max	2400	18,6	37	0,22	17,1	41	0,20
	min	1500	14,3	43	0,17	13,1	45	0,15

Incoming / outgoing water temperature 80/60 °C								
			Incoming air temp.= +15 °C			Incoming air temp. = +20 °C		
Type	Fan position	Airflow [m³/h]	Output [kW]	Outgoing air temp. [°C]	Water flow [l/s]	Output [kW]	Outgoing air temp. [°C]	Water flow [l/s]
AD210W	max	1200	7,7	34	0,09	7,0	37	0,08
	min	750	6,0	38	0,07	5,4	41	0,06
AD215W	max	1800	11,9	34	0,14	10,7	37	0,12
	min	1100	9,0	39	0,10	8,2	42	0,09
AD220W	max	2400	15,5	34	0,18	14,0	37	0,16
	min	1500	11,9	38	0,14	10,8	41	0,12

Incoming / outgoing water temperature 60/50 °C								
			Incoming air temp.= +15 °C			Incoming air temp. = +20 °C		
Type	Fan position	Airflow [m³/h]	Output [kW]	Outgoing air temp. [°C]	Water flow [l/s]	Output [kW]	Outgoing air temp. [°C]	Water flow [l/s]
AD210W	max	1200	5,7	29	0,13	5,0	32	0,11
	min	750	4,4	32	0,10	3,8	35	0,09
AD215W	max	1800	8,8	29	0,21	7,6	32	0,18
	min	1100	6,6	32	0,15	5,8	35	0,13
AD220W	max	2400	11,4	29	0,27	9,9	32	0,23
	min	1500	8,8	32	0,20	7,6	35	0,18

Incoming / outgoing water temperature 60/40 °C								
			Incoming air temp.= +15 °C			Incoming air temp. = +20 °C		
Type	Fan position	Airflow [m³/h]	Output [kW]	Outgoing air temp. [°C]	Water flow [l/s]	Output [kW]	Outgoing air temp. [°C]	Water flow [l/s]
AD210W	max	1200	4,6	26	0,05	3,8	29	0,04
	min	750	3,6	29	0,04	3,0	32	0,03
AD215W	max	1800	7,1	26	0,08	5,9	29	0,07
	min	1100	5,4	29	0,06	4,5	32	0,05
AD220W	max	2400	9,3	26	0,11	7,7	29	0,09
	min	1500	7,2	29	0,08	6,0	32	0,07

## Water pressure drop charts

### Water pressure drop over watercoil AD 200W

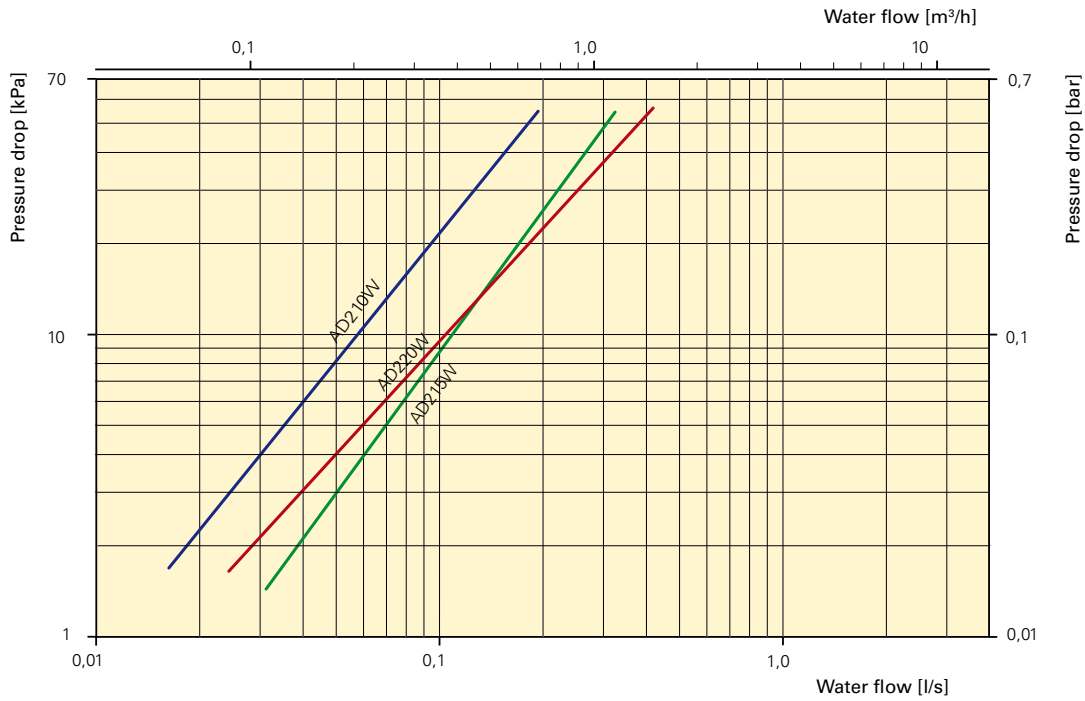

### Water pressure drop over controls and valves

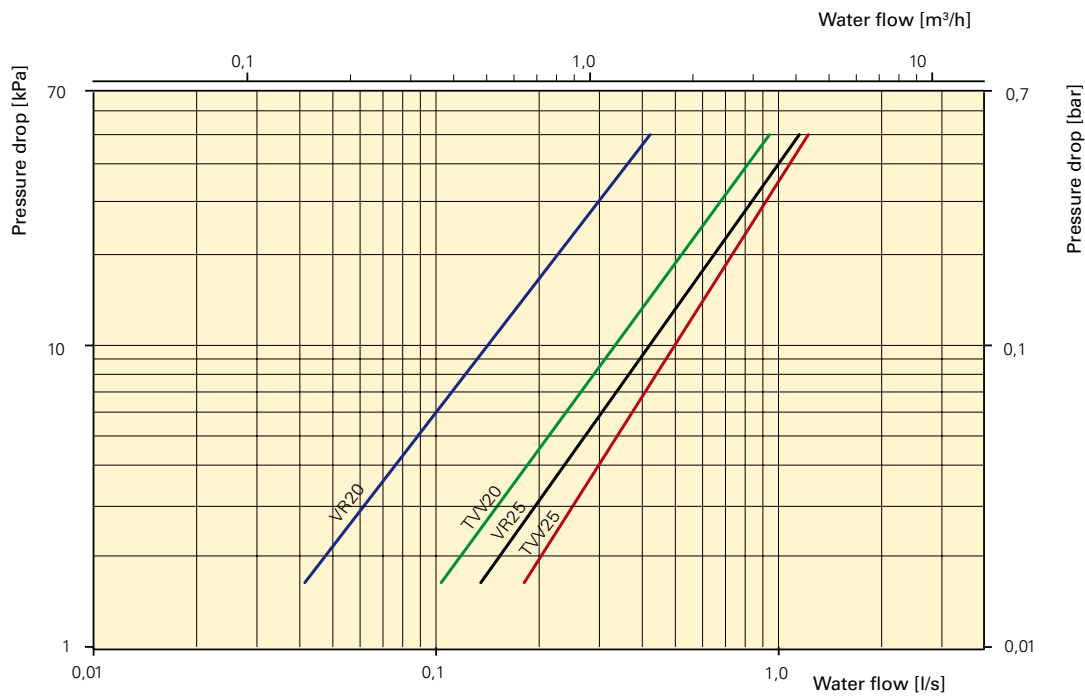

The pressure drop is calculated for an average temperature of 70 °C (PVV 80/60).  
For other water temperatures, the pressure drop is multiplied by the factor K.

Average temp. water °C	40	50	60	70	80	90
K	1.10	1.06	1.03	1.00	0.97	0.93