

## KD-fan Circular mixed flow fan

by Systemair

- Duct mounted mixed flow fan, 200 mm to 500 mm
- High efficiency - low noise
- Speed-controllable
- Integral thermal contacts
- Can be installed in any position
- Maintenance-free and reliable
- Mounting brackets fitted as standard



| Product Code | Voltage | Speed rpm | Airflow m <sup>3</sup> /sec@Static Pressure Pa. |        |        |        |        | Motor Data |      |       | dBA 3m | Speed Control |       |
|--------------|---------|-----------|---|--------|--------|--------|--------|------------|------|-------|--------|---------------|-------|
|              |         |           | 50 Pa   | 100 Pa | 150 Pa | 200 Pa | 300 Pa | FLC        | SC   | kW    |        | Elec          | Trans |
| KD200L       | 230     | 2565      | 0.340   | 0.315  | 0.275  | 0.245  | 0.150  | 1.14       | 4.7  | 0.256 | 53     | SC1,5         | RE1,5 |
| KD250M       | 230     | 2565      | 0.370   | 0.330  | 0.315  | 0.275  | 0.175  | 1.13       | 4.7  | 0.255 | 54     | SC1,5         | RE1,5 |
| KD250L       | 230     | 2595      | 0.525   | 0.495  | 0.455  | 0.420  | 0.330  | 1.61       | 7.0  | 0.37  | 55     | SC3,0         | RE3,0 |
| KD315M       | 230     | 2575      | 0.365   | 0.345  | 0.315  | 0.275  | 0.190  | 1.12       | 4.5  | 0.252 | 58     | SC1,5         | RE1,5 |
| KD315L       | 230     | 2590      | 0.565   | 0.542  | 0.505  | 0.465  | 0.370  | 1.62       | 7.2  | 0.372 | 53     | SC3,0         | RE3,0 |
| KD355S       | 230     | 2590      | 0.570   | 0.535  | 0.500  | 0.460  | 0.362  | 1.62       | 7.2  | 0.373 | 53     | SC3,0         | RE3,0 |
| KD315XL1     | 230     | 1375      | 0.685   | 0.585  | 0.450  | 0.225  | -      | 1.29       | 5.0  | 0.275 | 52     | SC3,0         | RTRE3 |
| KD355M1      | 230     | 1375      | 0.760   | 0.640  | 0.490  | 0.265  | -      | 1.3        | 5.0  | 0.275 | 50     | SC3,0         | RTRE3 |
| KD355XL1     | 230     | 1310      | 1.020   | 0.900  | 0.770  | 0.600  | 0.120  | 2.0        | 7.5  | 0.45  | 52     | SC3,0         | RTRE3 |
| KD400M1      | 230     | 1310      | 1.030   | 0.915  | 0.780  | 0.600  | 0.120  | 2.03       | 7.5  | 0.457 | 53     | SC3,0         | RTRE3 |
| KD400XL1     | 230     | 1270      | 1.590   | 1.465  | 1.310  | 1.155  | 0.785  | 4.3        | 11.0 | 0.893 | 58     | SC5,0         | RTRE5 |
| KD450M1      | 230     | 1305      | 1.700   | 1.570  | 1.410  | 1.225  | 1.020  | 4.67       | 11.0 | 0.922 | 60     |               | RTRE7 |
| KD450XL1     | 230     | 1290      | 2.235   | 2.095  | 1.940  | 1.790  | 1.435  | 6.16       | 15.0 | 1.398 | 61     |               | RTRE7 |
| KD500M1      | 230     | 1290      | 2.250   | 2.110  | 1.975  | 1.815  | 1.470  | 6.1        | 15.0 | 1.385 | 64     |               | RTRE7 |
| KD355XL3     | 400     | 1395      | 1.110   | 1.010  | 0.890  | 0.735  | 0.265  | 0.91       | 4.5  | 0.474 | 54     |               | RTRD2 |
| KD400M3      | 400     | 1390      | 1.135   | 1.020  | 0.905  | 0.735  | 0.230  | 0.93       | 4.5  | 0.475 | 54     |               | RTRD2 |
| KD400XL3     | 400     | 1325      | 1.650   | 1.535  | 1.400  | 1.235  | 0.800  | 1.6        | 4.5  | 0.861 | 57     |               | RTRD2 |
| KD450M3      | 400     | 1320      | 1.735   | 1.600  | 1.450  | 1.285  | 0.830  | 1.6        | 4.5  | 0.864 | 57     |               | RTRD2 |
| KD450XL3     | 400     | 1325      | 2.135   | 2.035  | 1.910  | 1.770  | 1.435  | 2.21       | 11.0 | 1.263 | 60     |               | RTRD4 |
| KD500M3      | 400     | 1330      | 2.210   | 2.100  | 1.970  | 1.830  | 1.485  | 2.23       | 11.0 | 1.267 | 60     |               | RTRD4 |

KD 200 - KD 355S

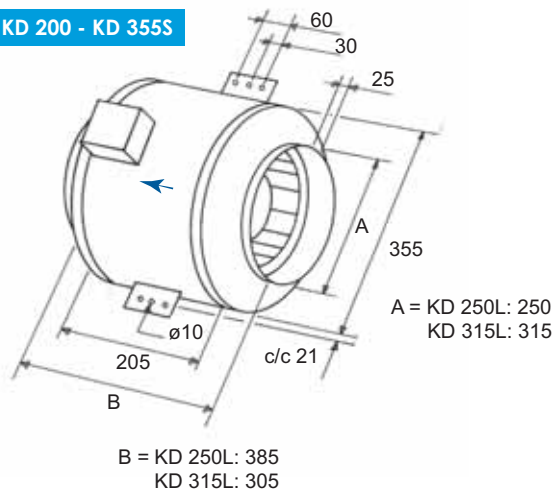

| KD         | ød  | L   | øD  | c/cH |
|------------|-----|-----|-----|------|
| 315XL1     | 312 | 484 | 455 | 518  |
| 400M1/M3   | 400 | 480 | 503 | 568  |
| 400XL1/XL3 | 400 | 602 | 560 | 625  |
| 500M1/M#   | 500 | 643 | 663 | 721  |

